

*Prestige* **diy**  
**PRODUCTS**

Innovative PVC Systems

**20**<sup>TH</sup>  
EDITION

BEAVER HOMES & COTTAGES  
**DESIGN BOOK**

[beaverhomesandcottages.ca](http://beaverhomesandcottages.ca)





**BEAVER HOMES MODEL PRICING - Web Links**



**GETAWAY COLLECTION**

**MODEL**

- SOLEIL
- COPPER CREEK II
- TAYLOR CREEK III
- BANCROFT
- KIPAWA II
- AMBERLY
- WASHAGO
- KIPAWA I
- CARIBOO
- SOLIEL DU MIDI
- MONACO
- SELKIRK
- TAYLOR CREEK II
- ASHLAND
- TRILLIUM II
- STILLWATER
- GATINEAU
- DORSET III
- MANATOULIN
- MAGNETAWAN
- BEAUPORT II
- RIDEAU
- STILLWATER I
- BANFF III
- DORSET IV
- BANFF II
- THOMPSON
- ASPEN II
- LINDHILL II
- DORSET II
- PEPPERMILL
- TRILLIUM
- LODGEPOLE
- DORSET I
- AURORA II
- CALEDON II
- LINDHILL I
- ASPEN I
- SILQUETTE II
- BEAUPORT I

**HIDEAWAY COLLECTION**

**MODEL**

- CAPILANO
- APSLEY
- BAYWOOD III
- BOWEN
- FULMORE
- BAYWOOD II
- PETIT SOLIEL
- FUTURA III
- BOREALIS
- LAKEWOOD I
- BAYWOOD I
- BEAUWATER
- YELLOW TAIL II
- BAYSIDE III
- YELLOW TAIL I

**NOSTALGIC COLLECTION**

- HARTLAND
- ROLLING MEADOW
- HOLLYHOCK
- KILLARNEY
- BARN SWALLOW
- ELK RIDGE
- INGLENOOK
- WHITETAIL CROSSING
- MADISON
- SEGUIN
- LIMBERLOST
- AVONLEA

**CARRIAGE HOUSE COLLECTION**

- COTSWOLD II
- COTSWOLD I
- WHISTLER II
- WHISTLER I
- LANGFORD
- WYNGATE
- TIDEWATER
- HARTLAND

**URBANESQUE COLLECTION**

**MODEL**

- FRIARSGATE
- MONTERA
- BELLAMERE
- MONTAGUE
- SINCLAIR
- EDDYSTONE
- FOXSTONE II
- SILVER MAPLE
- BELLEVUE
- FOXSTONE I
- MONTROSE
- ARDEN WOOD
- CORNERBROOK
- ROSEWOOD
- BIRCHLANE
- WOODRIDGE III
- SPRINGBANK
- KIMBERLY II
- HAWTHORNE II
- AMBERWOOD
- BROCKTON
- SAANICH
- CORTLAND
- DAUPHINE II
- BRAEMORE
- BRANDON II
- CYPRESS HILL II
- ELMHURST II
- OASIS

**COUNTRYISH COLLECTION**

**MODEL**













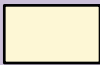



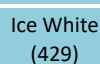





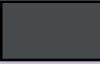

- CRANBERRY
- OTTER LAKE
- CHINOOK
- PRESCOTT
- GLENBRIAR II
- CRAIGLEITH
- BRIDLE TRAIL
- HAVEN CREST
- GLENBRIAR I
- HEARTHSTONE
- BROOKSIDE
- MAPLETON
- COTTONWOOD
- LINDSAY
- WILLOWCROFT

**Paint Specifications**  
**Pergola Planner**  
**Gable Styles**  
**Gable Specifications**

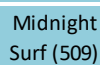
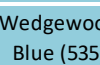
Index



**Stock Colours**

EURO FINISH	
LIGHT COLOURS (LRV 56 - 100)	Benjamin Moore Colours
	Jute AF-80    Mascarpone AF-20    Gray Sky 2131-70    Almond Bisque 269    Ashen Tan 996    Sterling 1591
	     
	Gentek Colours
	Almond (532)    Sandstone (540)    Ice White (429)    Maize (502)    Sandalwood (508)    Pearl (534)
	     
DARK COLOURS (LRV 0 - 55)	Benjamin Moore Colours
	Clay AF-155    River Rock 2139-10    Flint AF-560    Blue HC-159    Deep Creek 1477    Chelsea Gray HC-168
	     
	Gentek Colours
	Pebble (559)    Commercial Brown (562)    Midnight Surf (509)    Wedgewood Blue (535)    Sable (547)    Storm (570)
	     
THE CLASSICS	Benjamin Moore Colours
	Black (2132-10)    White Ice (OC-58)
	 
	Gentek Colours
Black (525)    Bright White (431)	
 	

**\* Custom Colours & Stains**  
Custom surcharge will apply  
Speak with your PrestigeDIY Representative for more information.

**Stock Pre-Finishing:**  
30% Surcharge on Material Value

**Dark Colours**  
\* Dark Colour Paints have heat reflective qualities.  
  
Standard **EURO FINISH** on all dark painted products.

**Stock Stains** Stain Finishes on Prestige DIY Products!

Stock Stain: 45% Surcharge on Material Value with Top Clear Coat



Cherry  
DD#9571

Teak  
DD#9512



Espresso  
DD#9575

Mahogany  
DD#9509



Espresso Stain

**IMPORTANT:**

- Colours may vary from above charts.
- Stain on PVC woodgrain texture will have a different tone than on smooth PVC materials
- Standard and custom colours are formulated to match **Gentek and Benjamin Moore** colour codes.

## Preparation & Application

**Your Prestige DIY Products™ are manufactured using premium free-foam cellular PVC and do not require painting to validate the warranty. If painting is preferred, please use the guidelines below.**

### Surface Preparation

Prestige DIY Products™ can be painted to achieve the desired look or accent colour of your home. To ensure good paint adhesion, the surface of the pvc product should be clean, dry, and free of dirt, mildew, chalk, grease and any other surface contaminants before paint application. Prior to cleaning it is a good practice to fill any holes and remove any marks or blemishes that may appear during the installation process with an exterior filler, (for example, sandable Bondo).

Cleaning can be accomplished using a cloth and a mixture of mild detergent and water. Other cleaning agents include a mild household spray cleaner, a degreaser, or alcohol.

### Coating Specification

A 100% acrylic latex or 100% acrylic latex with a urethane additive should be used to achieve superior coating durability and flexibility. Only light to medium coloured paints with a light reflective value (LRV) of 55 units or greater should be applied to Prestige DIY Products™. *Using a paint with a LRV below 55 units will void our product warranty.*

Paint manufacturer recommendations include priming with an exterior 100% acrylic latex primer, such as Zinsser Bulls Eye 123, followed by two coats of exterior 100% acrylic latex satin finish paint. Aquasur paint does not require a primer coat.

### Application

Apply paint when the air and surface temperatures are 2°C (35°F) or above, and when the air and surface temperatures will remain above this temperature for the next 24 hours. Avoid painting early in the morning or late in the day when dew and condensation are likely to form, or when rain or snow is expected. For the full life of the paint, always protect it from freezing.

Apply primer and topcoats using the following methods:

- Brush: Use a nylon/polyester brush.
- Roller: Use a 3/8" – 3/4" nap synthetic roller.
- Spray: Airless Pressure...2000 psi Tip...015"-.019"

Typical Drying Times (Dry Time at 25°C (77°F); 50% Relative Humidity):

- To the Touch: 30 minutes - To Recoat: 4 hours
- To Handle: 1 hour - To Full Cure: 30 days

### Considerations

- Higher quality paints typically outperform lower quality paints.
- Temperature, humidity, wind, and the amount of direct sunlight at time of application will affect paint drying times.
- Prestige Products™ are impermeable to moisture; it may take as long as 45 days for paint application to fully cure.
- Paint failures on wood are due primarily to moisture cycling. Since Prestige Products™ cannot absorb moisture, paints will adhere better and for a much longer time when applied to premium PVC versus wood.
- All painted Prestige Products ship with a small amount of touch up paint or stain top coat. Stain may require 2 or 3 coats to achieve desired tone.





**Rafters**

Length: \_\_\_\_\_  
 Height: \_\_\_\_\_  
 3.5"   
 5.5"   
 7.25"   
 Other: \_\_\_\_\_"   
 Width \_\_\_\_\_  
 1.5"   
 2"   
 Other: \_\_\_\_\_"   
 Stiffeners  
 None  Wood  Aluminum

**Ledger Board**

Height=Rafter Height +2"  
 Length: \_\_\_\_\_  
 Rafter Spacing (oc) \_\_\_\_\_  
 12"   
 16"   
 Other \_\_\_\_\_"

**Pergola Beam**

Height: \_\_\_\_\_  
 5.5"   
 7.25"   
 9.25"   
 Other: \_\_\_\_\_"   
 Width \_\_\_\_\_  
 2"   
 3"   
 4"   
 Other: \_\_\_\_\_"   
 Stiffeners  
 None  Wood  Aluminum

**Columns**

Quantity: \_\_\_\_\_  
 Width: \_\_\_\_\_ Height: \_\_\_\_\_  
 8"  8'   
 10"  10'   
 Other: \_\_\_\_\_"  Other: \_\_\_\_\_"   
 Style  
 Plain   
 4" craftsman skirts   
 Recessed Square Edge   
 4" craftsman skirts   
 Other   
 (attach column request sheet)

**Index**

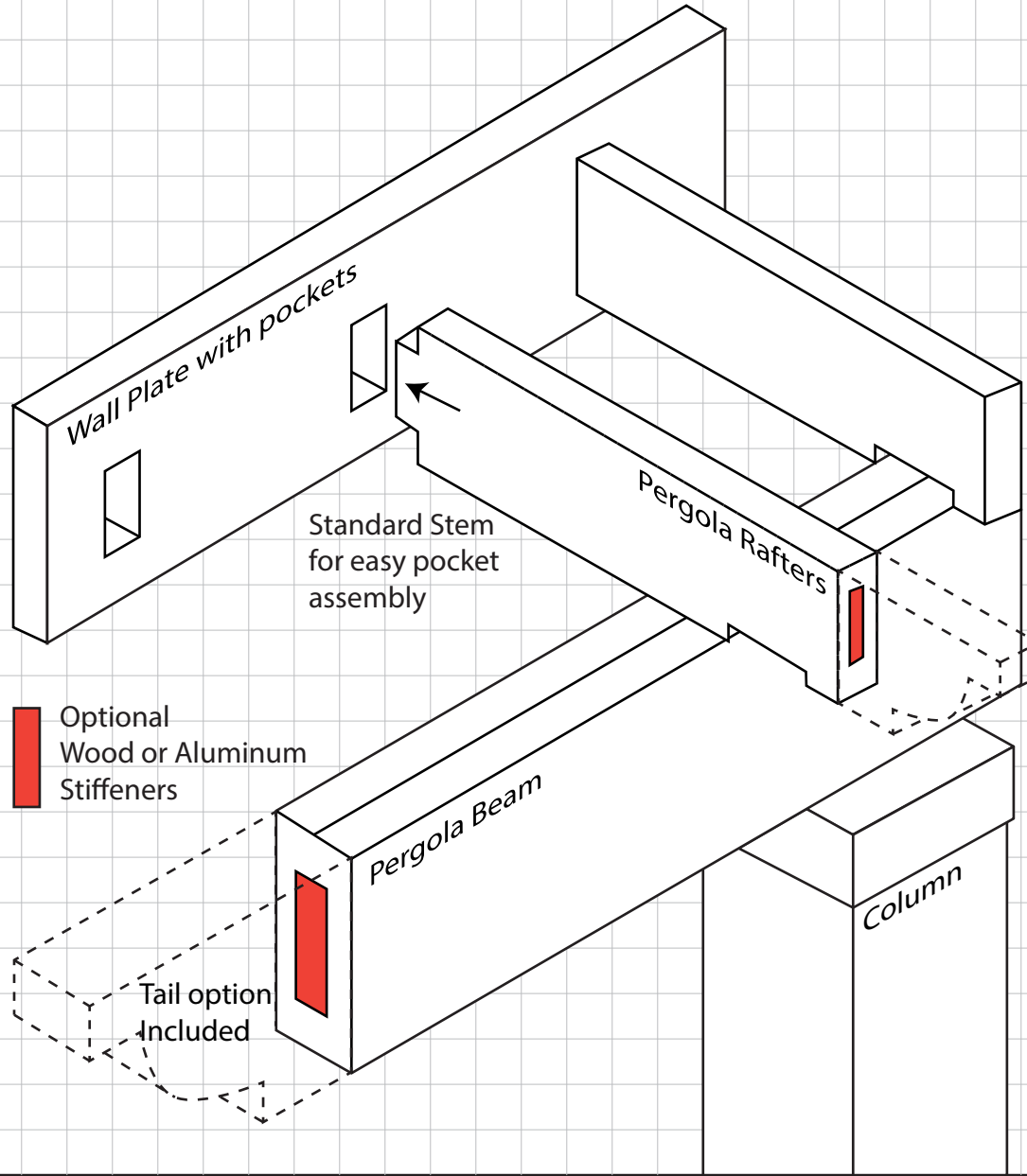

**Tail Styles**



**Notes:**

Blank area for notes.

**Pergola Project Planner**

[www.prestigedi.com](http://www.prestigedi.com)

<b>Dealer:</b>	<b>Client:</b>
<b>Address:</b>	<b>Address:</b>
<b>Phone:</b>	
<b>Email:</b>	



**Rafters**

Length: \_\_\_\_\_  
 Height: \_\_\_\_\_  
 3.5"   
 5.5"   
 7.25"   
 Other: \_\_\_\_\_"   
 Width \_\_\_\_\_  
 1.5"   
 2"   
 Other: \_\_\_\_\_"   
 Stiffeners  
 None  Wood  Aluminum

**Ledger Board**

Height=Rafter Height +2"  
 Length: \_\_\_\_\_  
 Rafter Spacing (oc) \_\_\_\_\_  
 12"   
 16"   
 Other \_\_\_\_\_"

**Pergola Beam**

Height: \_\_\_\_\_  
 5.5"   
 7.25"   
 9.25"   
 Other: \_\_\_\_\_"   
 Width \_\_\_\_\_  
 2"   
 3"   
 4"   
 Other: \_\_\_\_\_"   
 Stiffeners  
 None  Wood  Aluminum

**Columns**

Quantity: \_\_\_\_\_  
 Width: \_\_\_\_\_ Height: \_\_\_\_\_  
 8"  8'   
 10"  10'   
 Other: \_\_\_\_\_"  Other: \_\_\_\_\_"   
 Style  
 Plain   
 4" craftsman skirts   
 Recessed Square Edge   
 4" craftsman skirts   
 Other   
 (attach column request sheet)

Index

# Pergola Project Planner

[www.prestigedi.com](http://www.prestigedi.com)

**Tail Styles**



**Notes:**

<b>Dealer:</b>	<b>Client:</b>
<b>Address:</b>	<b>Address:</b>
<b>Phone:</b>	
<b>Email:</b>	

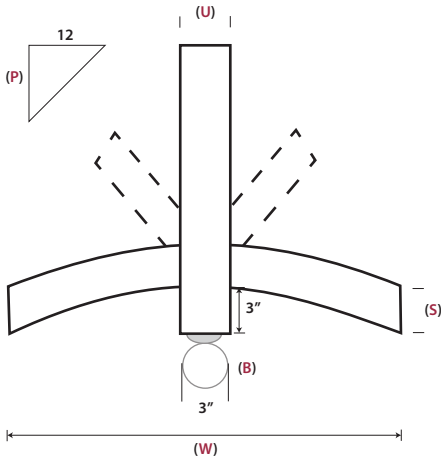

**ICa**

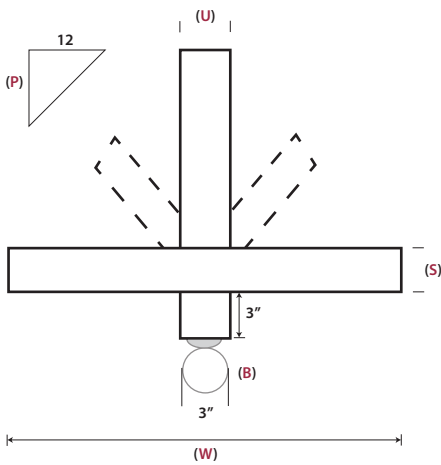

**IC**

**G1**



**G3**

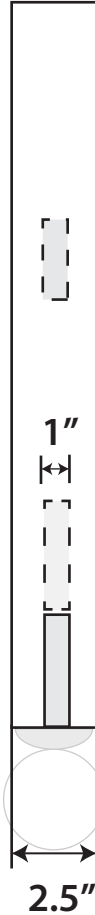

**G4**

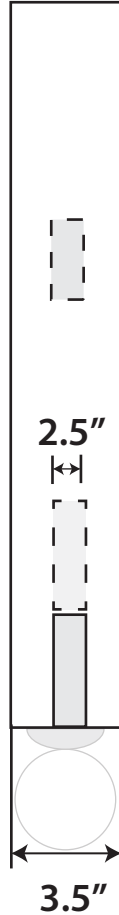

**G6**

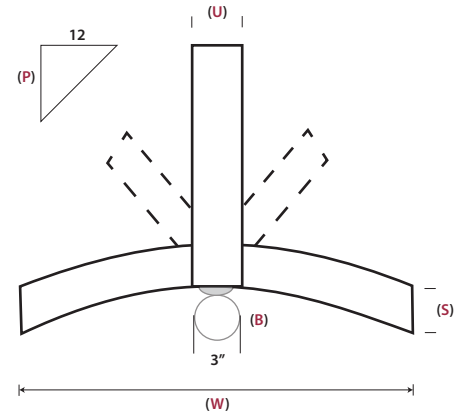
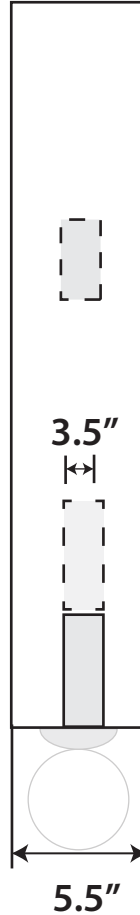

**ITa**

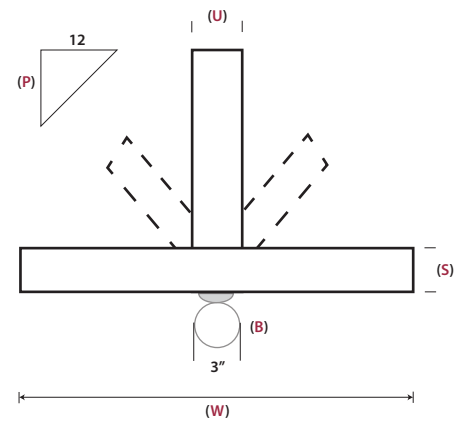

**IT**

**Understanding your Prestige Gable Detail product code.**

**G1 Product Codes**

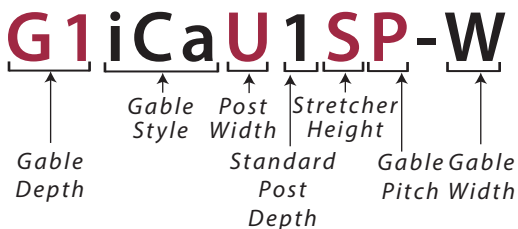

**G3 Product Codes**

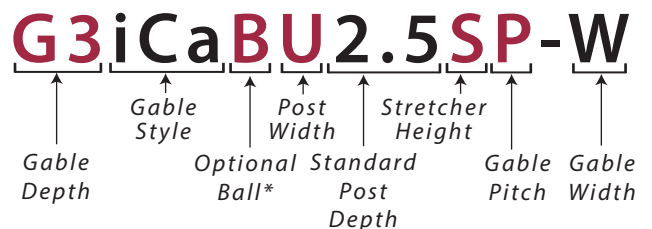

\* Only applicable to those Gable Detail Styles that include these elements.

For additional detailed specifications on each gable, please visit the Gable Resource section at [www.prestigediy.com](http://www.prestigediy.com).



Gable Detail Styles

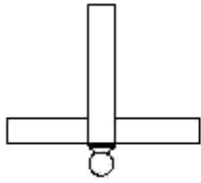

D - 1  
(iT-b)

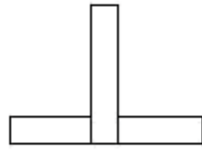

D - 2  
(iT)

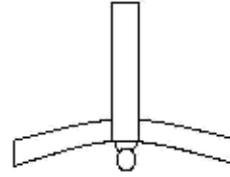

D - 3  
(iTa-b)

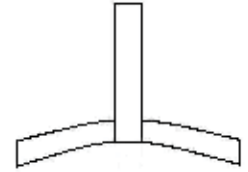

D - 4  
(iTa)

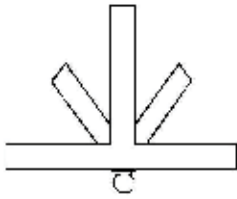

D - 5  
(iTv-b)

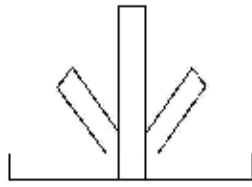

D - 6  
(iTv)

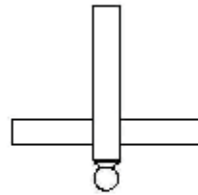

D - 7  
(iC-b)

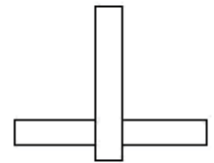

D - 8  
(iC)

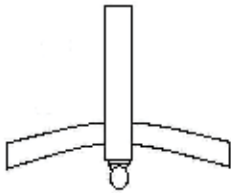

D - 9  
(iCa-b)

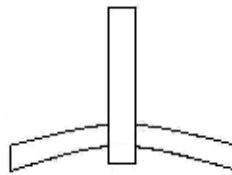

D - 10  
(iCa)

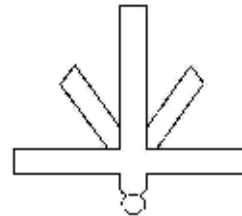

D - 11  
(iCv-b)

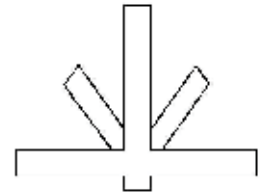

D - 12  
(iCv)

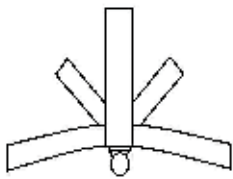

D - 13  
(iTVa-b)

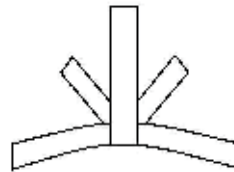

D - 14  
(iTVa)

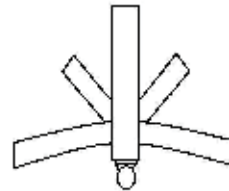

D - 15  
(iCVa-b)

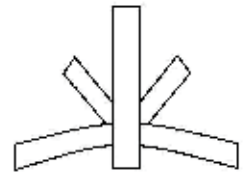

D - 16  
(iCVa)

**Each style is available in both G1 & G3 details.\***

\*See specifications sheet for G1 & G3 details. (Page 24)

Many can be Flat Packed for easy shipping.

For custom orders, please contact your local contractors desk or visit us at [www.prestigediy.com](http://www.prestigediy.com) to request quote.

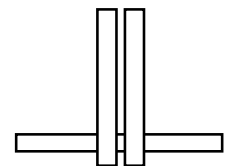

D - 48  
(iCd)