



## *The Prestige Advantage*

### **Beautiful**

- Classic Architectural Look
- No Visible Fasteners
- Wide Assortment of Styles

### **Easy Installation**

- Sold Individually or in Kits
- No Special Tools Needed
- Flat-Pack for Safe & Easy Transportation

### **Virtually Maintenance Free**

- Free-Foam Cellular PVC Construction
- Weather, Decay and Insect Resistant
- Paint Friendly with Acrylic Latex Paints



**Prestige Soffit Panels™** are an improved soffit system that allows for maximum airflow. Our vented soffit has an 8/4 repeating pattern that provides 10 square inches of free air space per lineal foot. Our innovative nature allowed for another solution for a quick and easy installation.

[www.prestigediy.com](http://www.prestigediy.com)

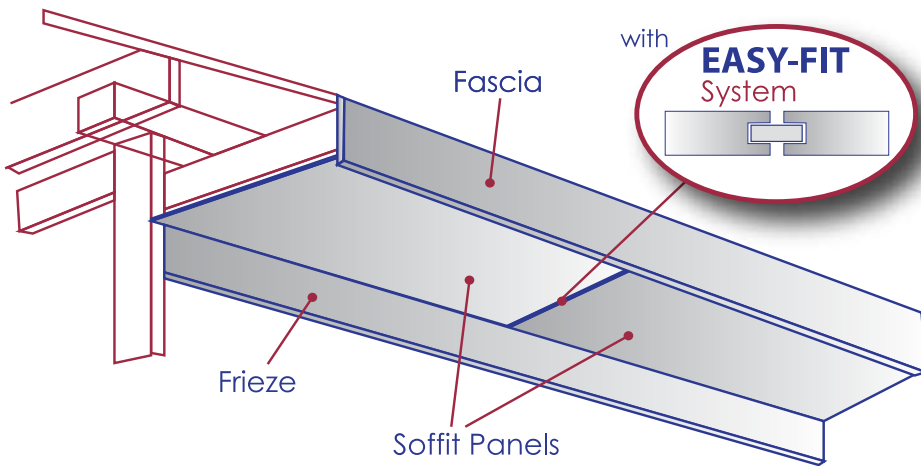

## Available Panels

### Solid Panel



### Vented Panel

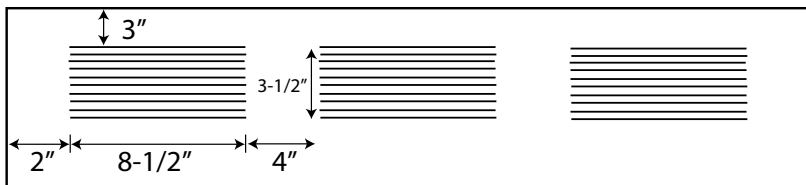

### Transition Corner Panel

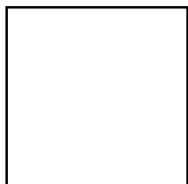

\*Adjustable to fill soffit angles

### PVC Panel Spline Bar



**Note:** Our vented soffit has an 8/4 repeating pattern to provide 10 Sq. in. for free air space per lin. ft.

### Standard Measurements for Prestige Soffit Panels™

Panel Thickness:	1/2"
Panel Widths:	12", 16" & 24"
Panel Lengths:	48"
PVC Spline:	3/8" x 1"

### What Makes the Prestige Soffit Panels Different?

- Standard 12", 16" and 24" widths, 4' lengths
- Architectural accent joints located at 4' intervals
- Easy-Fit system installs without the need for joint finishing
- Easy, quick installation
- Made from premium 1/2" PVC
- Transition Corner Panels allow for easy installation
- Custom radius options available
- Available in natural white or painted to match